

# PolarSpeed®-S/PolarSpeed®-S-AR

---

## PRODUCT SPECIFICATIONS

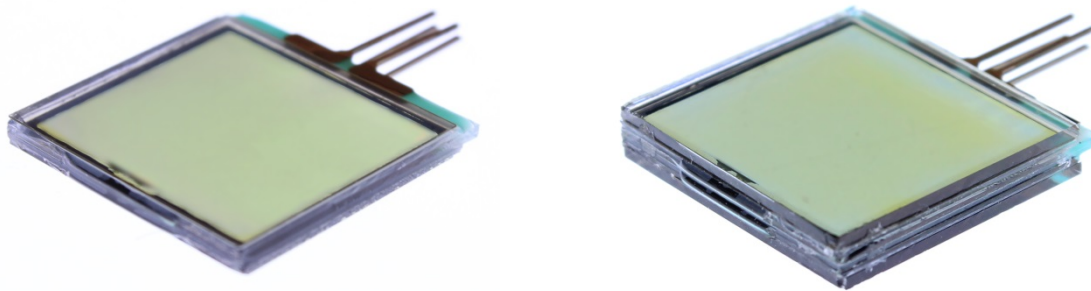

### Content

1. Revision history .....	2
2. Product description .....	2
3. Ordering information .....	2
4. Custom designing .....	2
5. General specification .....	3
6. Absolute maximum ratings .....	3
7. Electro-optical specification .....	3
8. Graphs .....	4
9. Drive voltage and recommended controller .....	7
10. Measurement methods and definitions .....	8
11. Mechanical dimensions .....	10
12. Electrical connection and wiring diagram .....	12
13. Handling precautions .....	13

## 1. Revision history

<i>Revision</i>	<i>Revision date</i>	<i>Revision content</i>
Initial release	2013-09-23	-
-	-	-

## 2. Product description

The PolarSpeed®-S (PolarSpeed® Shutter) is a polarizer-based nematic liquid crystal (LC) optical shutter that controls the light transmittance by an externally applied drive voltage. Compared to conventional mechanical shutters, LC shutters are completely vibration-free and contain no moving parts.

The shutter consists of a polarization modulator in the form of two LC cells positioned between crossed linear polarizers. Applying the drive voltage reorients the birefringent LC molecules, changing the phase retardation of light passing through the LC cells. This results in a change in transmittance of light passing through the full shutter structure. Analogue gray-scale operation between fully open and closed states is realized by voltage amplitude modulation. Compared to other FOS models, PolarSpeed® technology enables rapid switching in both directions, open-to-closed as well as closed-to-open.

For demanding optical applications, the PolarSpeed®-S-AR is supplied with an optical quality, high-efficiency AR (anti-reflective) cover glass laminated to both sides of the shutter. This configuration minimizes surface reflection, beam deviation, and wavefront aberration.

## 3. Ordering information

<i>Product</i>	<i>Part number</i>
13x15_PolarSpeed®-S	LCT-012
13x15_PolarSpeed®-S-AR	LCT-013
1x1_PolarSpeed®-S	LCT-020
1x1_PolarSpeed®-S-AR	LCT-021
2x2_PolarSpeed®-S	LCT-028
2x2_PolarSpeed®-S-AR	LCT-029
D1_PolarSpeed®-S	LCT-054
D1_PolarSpeed®-S-AR	LCT-055
D2_PolarSpeed®-S	LCT-062
D2_PolarSpeed®-S-AR	LCT-063
LCC-230 Controller	LCT-030

To purchase or for more information, please contact us at: [info@lc-tec.se](mailto:info@lc-tec.se).

## 4. Custom designing

Customers not finding their required shutter properties are advised that other FOS models are available and that further optimization and custom designing are possible, both in terms of electro-optical properties and mechanical dimensions (up to 14"x16" size).

## 5. General specifications

	<i>PolarSpeed®-S</i>	<i>PolarSpeed®-S-AR</i>
<b>Technology</b>	Nematic LC	Nematic LC
<b>Mode of operation<sup>1</sup></b>	PolarSpeed®	PolarSpeed®
<b>Side 1 polarizer transmission axis<sup>2</sup></b>	+45°	+45°
<b>Side 2 polarizer transmission axis<sup>2</sup></b>	-45°	-45°
<b>LC cell substrate material</b>	Polished soda lime glass	Polished soda lime glass
<b>Polarizer type and material</b>	Absorptive type polymer	Absorptive type polymer
<b>AR substrate material</b>	N/A	Polished soda lime glass
<b>Scratch resistance</b>	≥3H	N/A

## 6. Absolute maximum ratings<sup>3</sup>

	<i>PolarSpeed®-S</i>	<i>PolarSpeed®-S-AR</i>
<b>Operating temperature<sup>4</sup></b>	-10°C to +60°C	-10°C to +60°C
<b>Storage temperature<sup>4</sup></b>	-10°C to +60°C	-10°C to +60°C
<b>Drive voltage amplitude</b>	≤24V	≤24V
<b>Drive voltage frequency</b>	≤1kHz AC square waveform	≤1kHz AC square waveform

## 7. Electro-optical specifications<sup>5</sup>

	<i>PolarSpeed®-S</i>	<i>PolarSpeed®-S-AR</i>
<b>Open state transmittance<sup>6</sup></b>	≥37.5% @ V <sub>D</sub> =24V	≥36.5% @ V <sub>D</sub> =24V
<b>Open state color</b>	u'=0.204 ± 0.01 v'=0.506 ± 0.01	u'=0.204 ± 0.01 v'=0.506 ± 0.01
<b>Contrast</b>	≥300:1 @ V <sub>D</sub> =24V	≥300:1 @ V <sub>D</sub> =24V
<b>Angular dependence</b>	Normally or close to normally incident light only recommended	Normally or close to normally incident light only recommended
<b>T<sub>50</sub> voltage</b>	2.19V ± 0.2V	2.19V ± 0.2V
<b>Closing time (T<sub>100</sub>-T<sub>10</sub>)</b>	≤30μs @ V <sub>D</sub> =24V	≤30μs @ V <sub>D</sub> =24V
<b>Opening time (T<sub>0</sub>-T<sub>90</sub>)</b>	≤30μs @ V <sub>D</sub> =24V	≤30μs @ V <sub>D</sub> =24V
<b>Maximum frame rate<sup>7</sup></b>	540FPS	540FPS
<b>Reflectance per surface</b>	≤2%	≤0.5%
<b>Surface quality</b>	N/A	60/40 scratch/dig
<b>Beam deviation</b>	N/A	≤1 arc min
<b>RMS average power consumption<sup>8</sup></b>	≤12mW	≤12mW
<b>Peak current<sup>8</sup></b>	≥28mA	≥28mA

<sup>1</sup> Patent No. US 8,023,052 and US 8,184,215.

<sup>2</sup> Refer to drawing in section 10.5.

<sup>3</sup> Reliability tests performed over a range of environmental conditions according to standard IEC 61747-5.

<sup>4</sup> Dry, no condensation.

<sup>5</sup> The specified values are valid for the 1x1 size and measured at room temperature (23°C ± 3°C).

<sup>6</sup> Refers to unpolarized incident light, the corresponding value for linearly polarized light is typically 75%.

<sup>7</sup> LC relaxation reset time required between switches.

<sup>8</sup> As measured with f=60Hz, V<sub>D</sub>=12V AC square drive waveform with transition slew rate of 3.5V/μs. Actual figures will vary with waveform slew rate, amplitude, frequency, and shutter size. Also see section 9.

## 8. Graphs (typical PolarSpeed®-S values @ room temperature and $V_D=24V$ unless other specified)

### 8.1. Open and closed state transmittance vs. wavelength

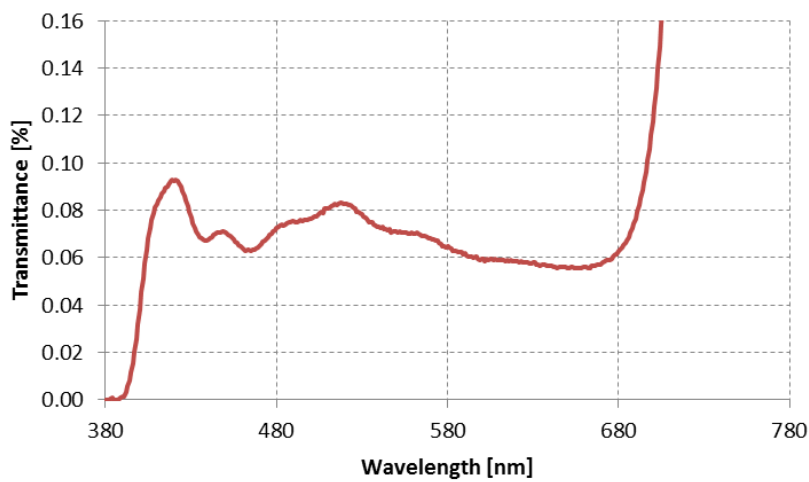
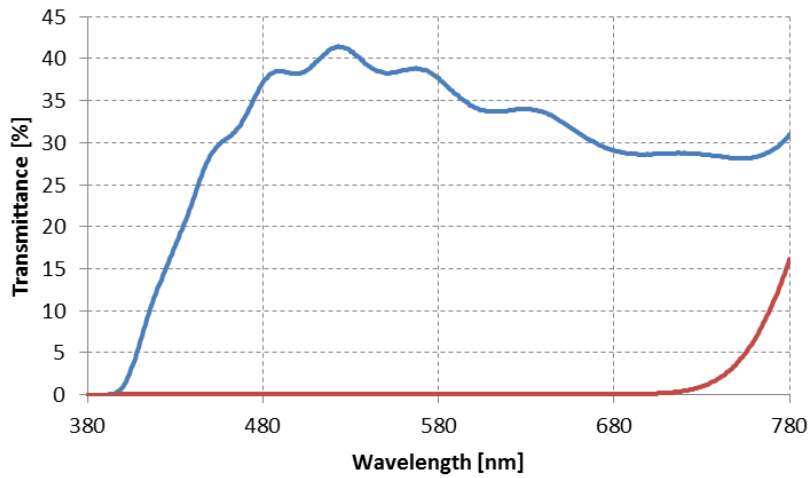

### 8.2. Transmittance vs. drive voltage amplitude (refers to cell 1, cell 2 @ $V_D=0$ )

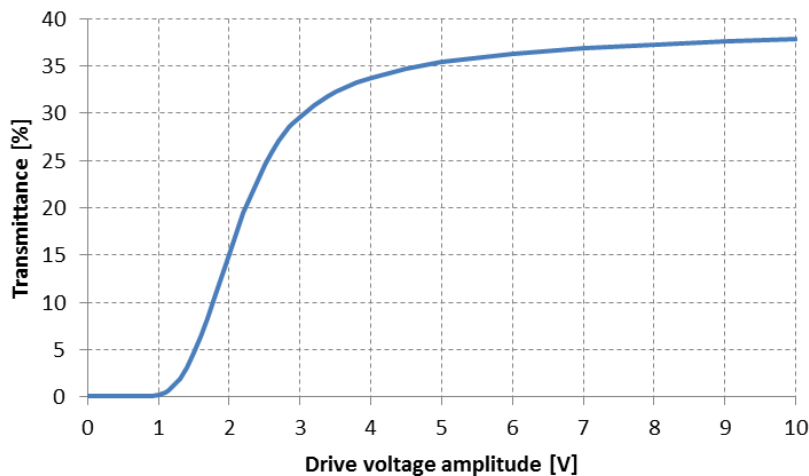

**8.3. Closing time at room temperature, normalized transmittance vs. time (cell 2 drive voltage switched on at t=0)**

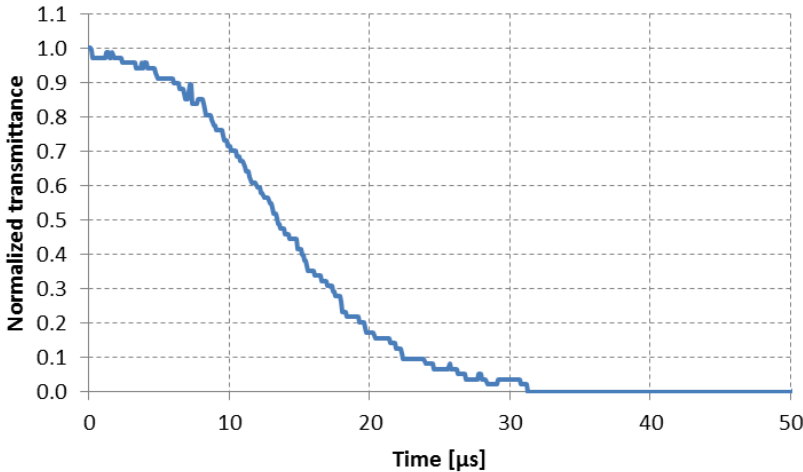

**8.4. Closing time vs. temperature**

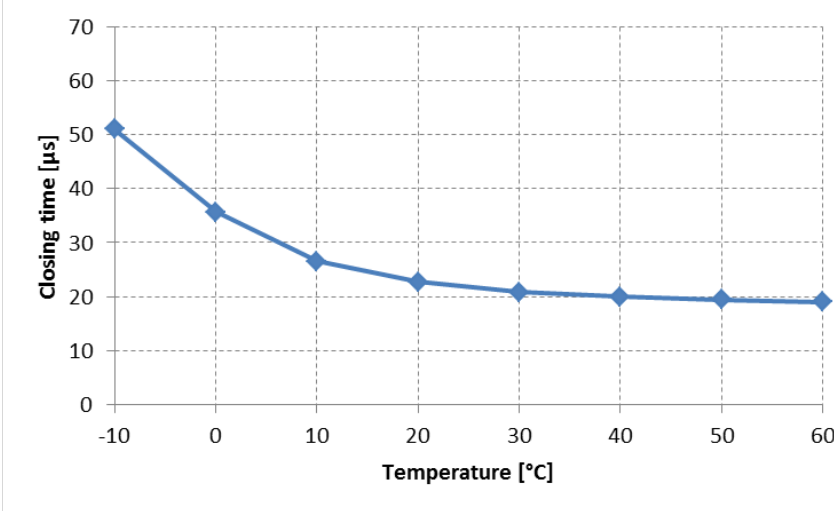

**8.5. Opening time at room temperature, normalized transmittance vs. time (cell 1 drive voltage switched on at t=0)**

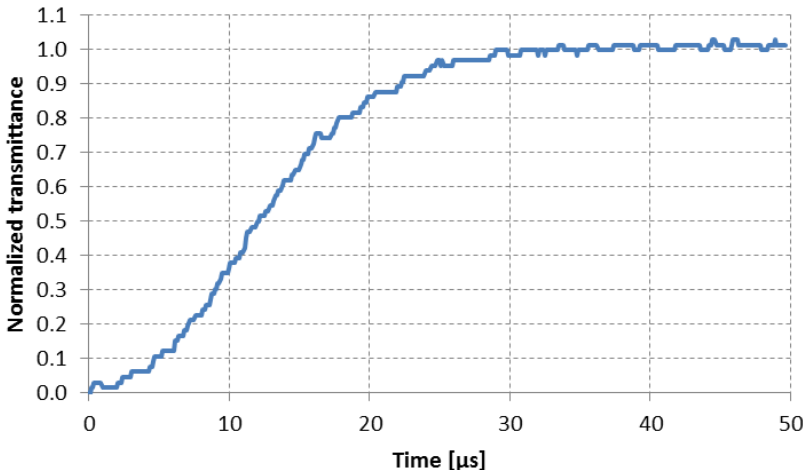

**8.6. Opening time vs. temperature**

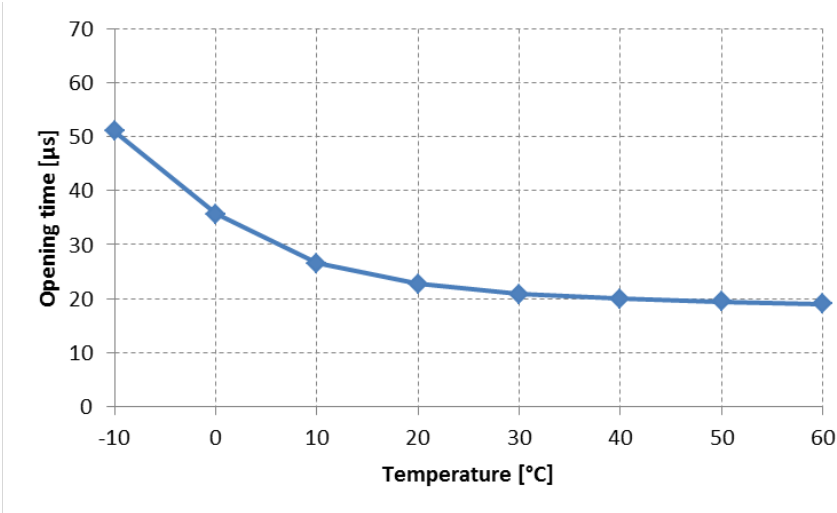

**8.7. Maximum frame rate vs. temperature**

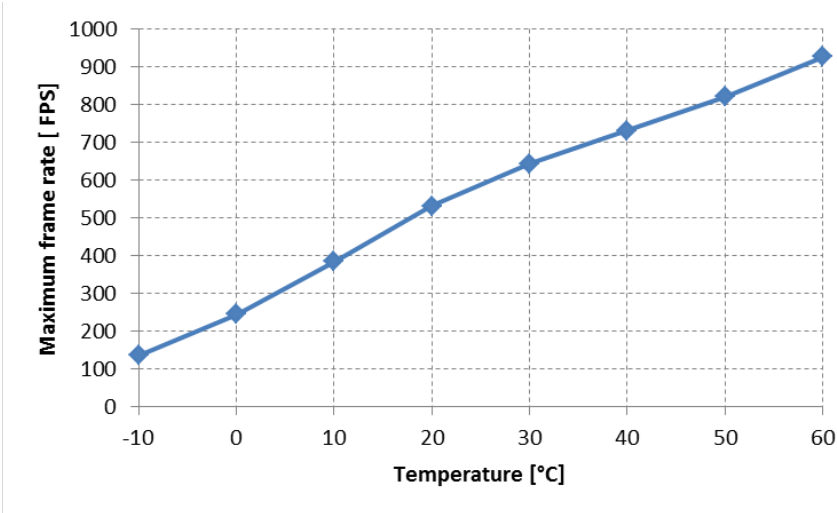

## 9. Drive voltage and recommended controller

In order to achieve rapid switching in both directions two LC cells are arranged in optical series in such way that during one of the subframes the second cell compensates the first one to exhibit a combined property of not changing the state of polarization of normally incident light passing through them. This compensation principle holds for the field-off state of both cells, and is also valid if the same voltage level is applied to both cells as well as if the applied voltage is changed from one level to another and the LC mixture in the cells relaxes to the new voltage level.

The figure below illustrates the specific dual-cell drive waveforms that results in rapid switching in both directions. The same voltage amplitude should be applied to both cells. The duration  $t_0$  to  $t_1$  (and  $t_3$  to  $t_4$ ) must be longer than the LC response time ( $100\mu\text{s}$  recommended). The duration of  $t_1$  to  $t_2$  and ( $t_4$  to  $t_5$ ) is given by the desired frame rate, but must be longer than the LC relaxation time.

In order to prevent ion migration within the LC layer that might impair shutter performance and lifetime, it is recommended to ensure that there is no net DC bias present in the drive signal.

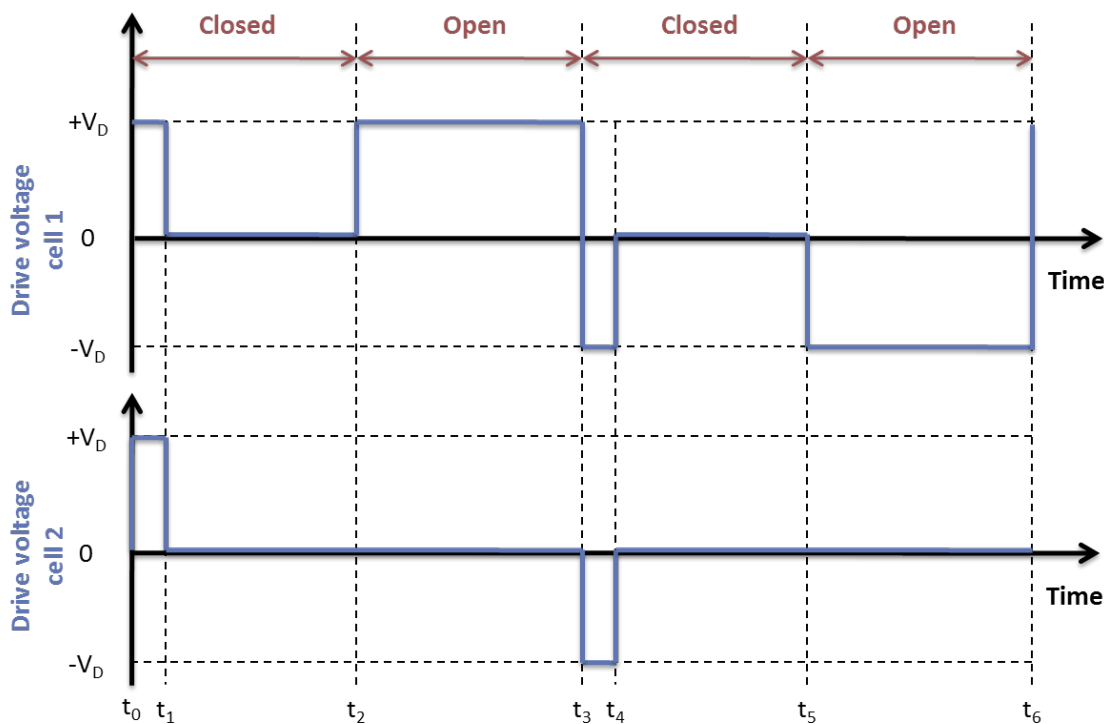

The LCC-230 (*LC-Tec Part number LCT-030*) is a flexible, full-featured liquid crystal controller specifically designed to drive all FOS, X-FOS, and PolarSpeed® models. The LCC-230 incorporates two independent LC channels, each with  $30V_{\text{RMS}}$  of range and fully short-circuit protected. The controller is operated by the LCDriver2 application via a full-speed USB 2.0 compliant interface. LCDriver2 permits dynamic editing of programs up to 96 lines in length. Three trigger modes (internal, line, program) determine how program lines are executed. Up to nine programs may also be pre-stored on the LCC-230 for stand-alone operation. See user manual for further information.

**Note:** Customer-developed LC drive stages must be able to deliver at least the peak current of the specific FOS device to be driven. Output-stage ballast capacitors with a maximum ripple current rating at least three times the peak current is recommended.

## 10. Measurement methods and definitions

### 10.1. Transmittance, color and contrast

The transmittance is defined as the luminous transmittance of collimated unpolarized light passing perpendicularly through the shutter according to:

$$T = \frac{\int_{380}^{780} T(\lambda)D(\lambda)P(\lambda)d\lambda}{\int_{380}^{780} D(\lambda)P(\lambda)d\lambda}$$

where  $T(\lambda)$  is the transmittance function of the shutter,  $D(\lambda)$  is the illuminant spectral distribution, and  $P(\lambda)$  is the photopic response of the human eye. All transmittance values specified are based on the standard illuminant CIE E (equal-energy for all wavelengths). The corresponding color is mathematically described using the color matching functions of the CIE 1931 Standard Colorimetric Observer, and is represented by a point in the  $u',v'$  chromaticity coordinate system.

The contrast is defined as the ratio of the transmittance of the open, non-compensating state to that of the closed, compensating state according to:

$$C = \frac{T_{open (non-compensating)}}{T_{closed (compensating)}}$$

Since the transmittance depends on applied drive voltage, also the contrast is a function of the voltage and usually increases with increasing amplitude.

### 10.2. Angular dependence

The transmittance is not only a function of light wavelength and applied drive voltage. Since the phase retardation induced by the LC cell also depends on the angle between the direction of light and the long axis of the LC molecules, the transmittance of the shutter can for a given angle of incidence be described by:

$$T = T(\theta, \phi, \lambda, V_D)$$

where  $\theta$  is the polar angle between the light exit direction and the normal vector to the surface, and  $\phi$  is the azimuth angle of the light exit direction as specified below.

The angular dependence of the contrast between the open and closed states in diffuse light is illustrated in a so-called polar plot as shown below. Iso-contrast lines describe the contrast values at various angles. The center of the plot corresponds to light exiting perpendicularly from the shutter surface.

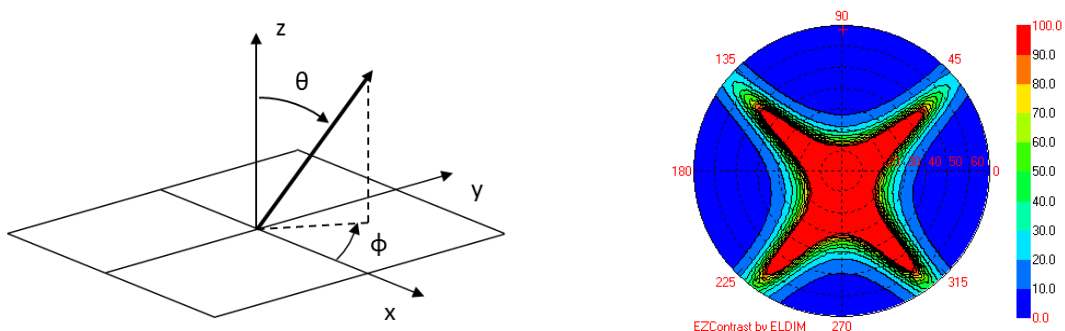



### 10.3. T<sub>50</sub> voltage

The T<sub>50</sub> voltage represents the point on the transmittance vs. applied drive voltage curve where the shutter is switched midway between closed and open states, i.e. the voltage that corresponds to a transmittance level of 50% of the normalized open state transmittance.

### 10.4. Switching times

Two switching times are associated with the shutter. The time for closing the shutter, closing time (also called the response time or t<sub>on</sub> time), is defined as the time it takes for the shutter to switch from 100% to 10% (T<sub>100</sub>-T<sub>10</sub>) of its static open transmittance after the drive voltage is applied to cell 2. The corresponding time for opening the shutter, opening time (also called the response time or t<sub>on</sub> time), is defined as the time it takes for the shutter to switch from 0% to 90% (T<sub>0</sub>-T<sub>90</sub>) of its static open transmittance after the drive voltage is applied to cell 1.

PolarSpeed® technology enables rapid switching in both directions. The opening time as well as the closing time decrease with increasing drive voltage amplitude and increasing temperature. Also the maximum frame rate increases with increasing temperature. See section 9 for information about required drive signals.

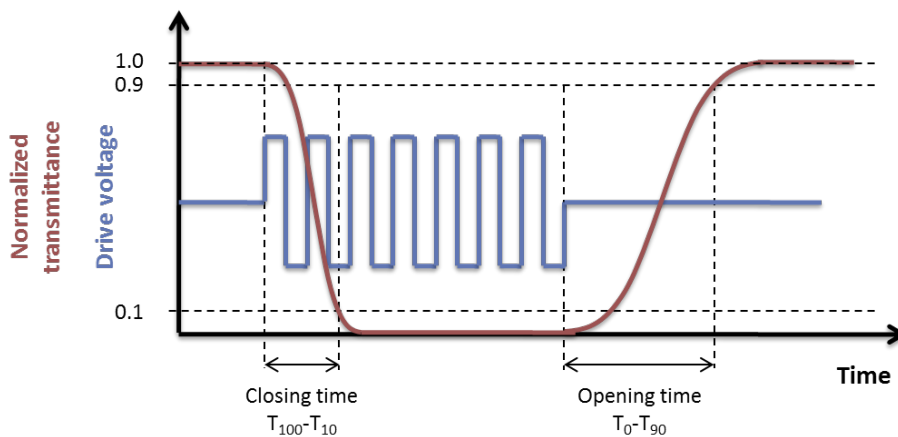

### 10.5. Polarizer transmission axis

#### PolarSpeed®-S & PolarSpeed®-S-AR

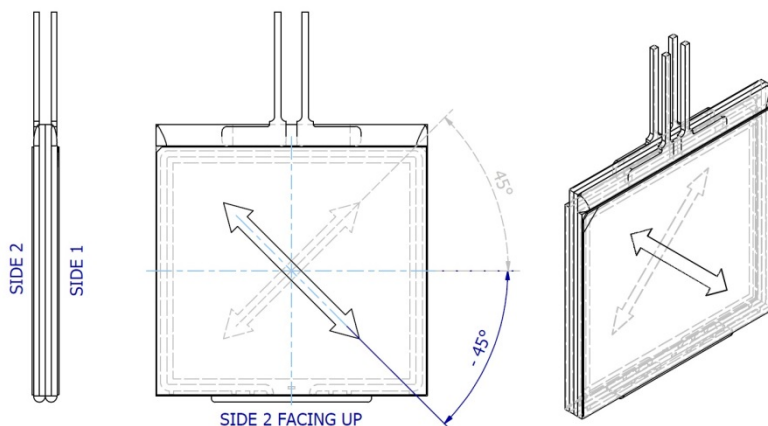

## 11. Mechanical dimensions<sup>9</sup>

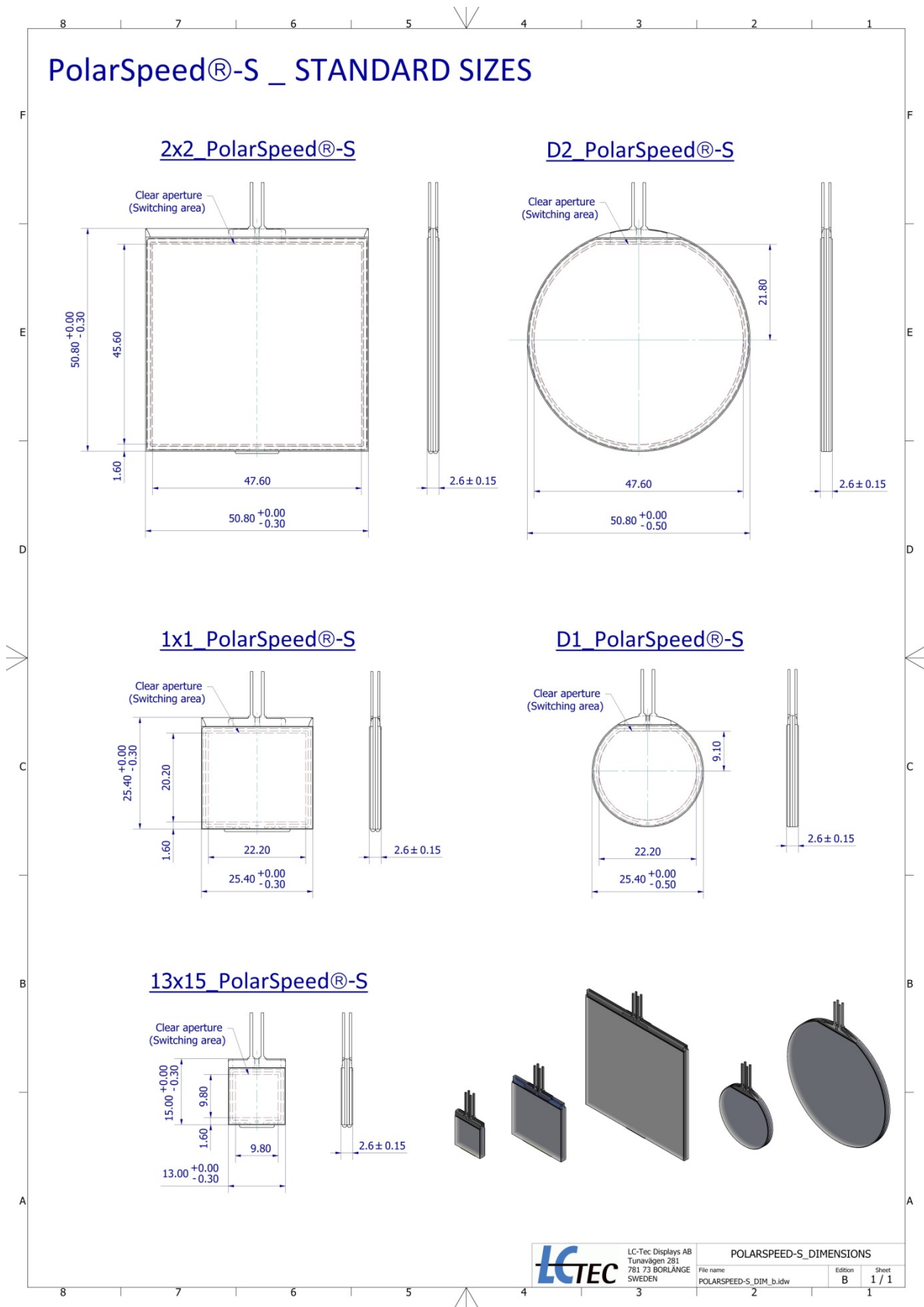

<sup>9</sup> Refers to available standard sizes. Custom designing up to 14" x 16" size is offered.

# PolarSpeed®-S-AR \_ STANDARD SIZES

## 2x2\_PolarSpeed®-S-AR

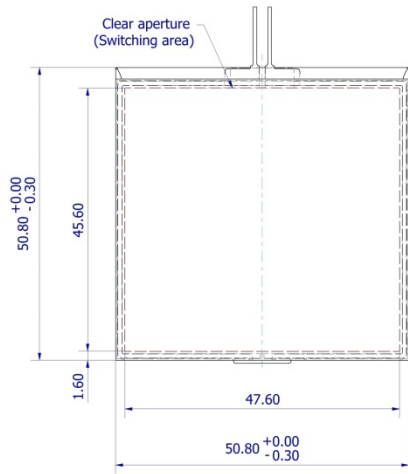

## D2\_PolarSpeed®-S-AR

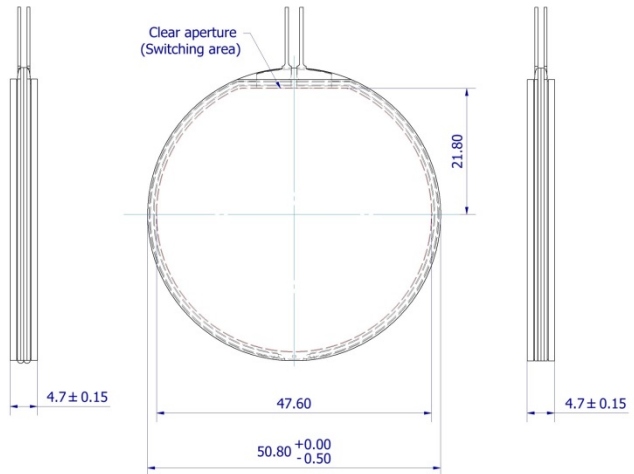

## 1x1\_PolarSpeed®-S-AR

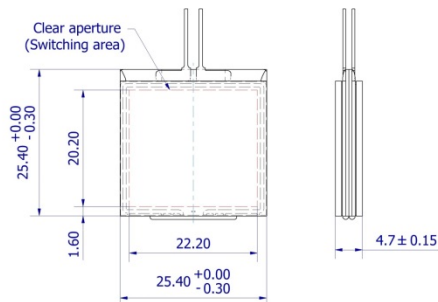

## D1\_PolarSpeed®-S-AR

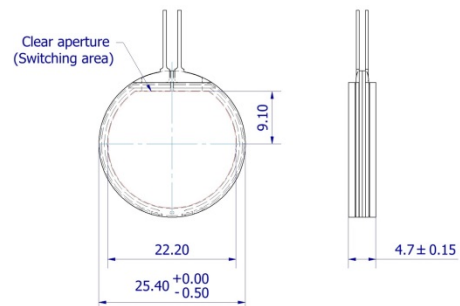

## 13x15\_PolarSpeed®-S-AR

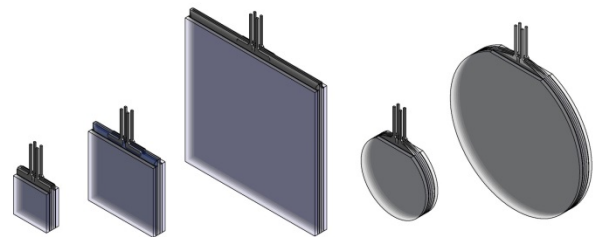
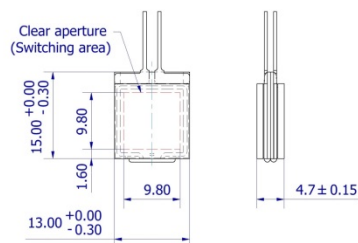

LC-Tec Displays AB  
Tunavägen 281  
781 73 BORLANGE  
SWEDEN

POLARSPEED-S-AR\_DIMENSIONS

File name	Edition	Sheet
POLARSPEED-S-AR_DIM_b.idw	B	1 / 1

## 12. Electrical connection and wiring diagram

The shutter is supplied with contact pins as illustrated in the drawing below. The desired drive waveforms should be applied to the LC cells as indicated in the wiring diagram. Specific dual-cell waveforms are required as described in section 9. The pin design is compatible with 2.54mm pitch connectors (for example the *Molex Part Number 90123-0102*). Customers can also solder wires to the pins or connect them directly to a dedicated PCB (printed circuit board) if desired.

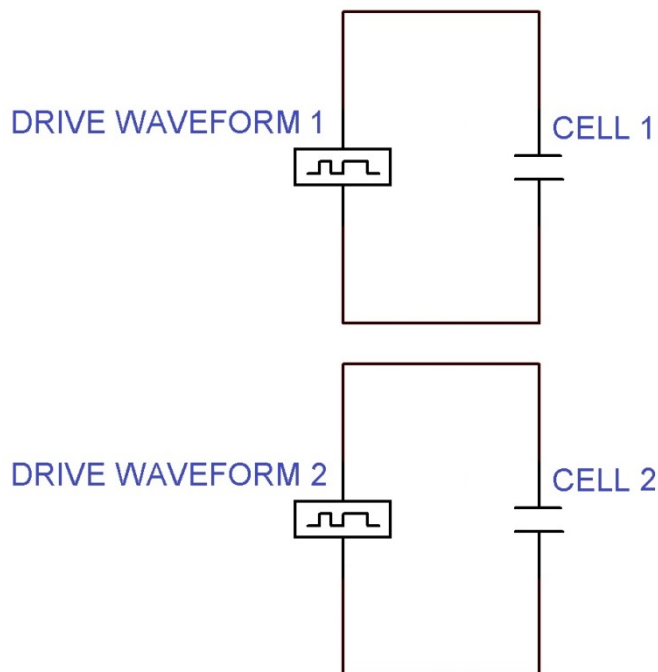
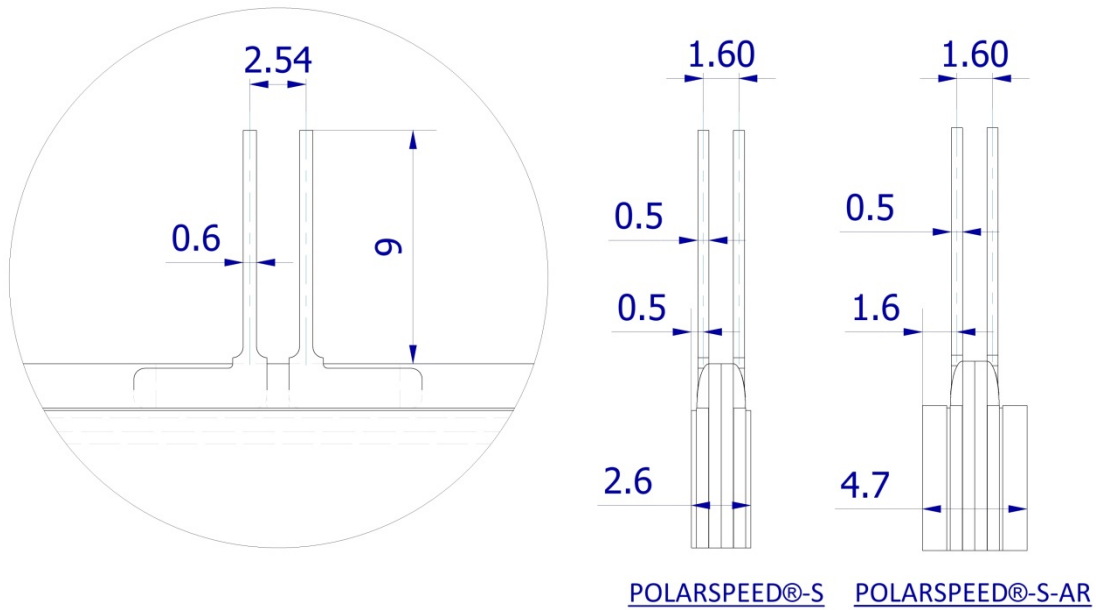

## 13. Handling precautions

The following provides recommendations for handling of this product.

### LC shutter handling and cleaning precautions

- A protective film is supplied on both sides of the shutter and should be left in place until the shutter is required for operation.
- Even though the polarizers have a hard-coating on the outer surface, please guard against scratching, do not rub with abrasives.
- Keep the shutter surface clean. Do not touch without protective gloves.
- Should the surface become contaminated, wipe lightly with a soft cloth moistened with solvent (isopropyl alcohol or ethyl alcohol) in order to clean the shutter surface.
- Do not wipe the shutter surface with dry or hard materials that may damage the surface. Do not use the following solvents for cleaning: water, aromatics, acetone or other ketone.
- Since this shutter contains glass substrates, avoid applying mechanical shock or pressure. Do not drop, bend, twist or press on the shutter.

### Storage

- Avoid exposure to direct sunlight or high temperature and humidity. Recommended storage conditions: temperature range +5°C to +45°C with humidity <60%RH.
- Do not store the shutter near organic solvents or corrosive gases.
- Keep the shutter protected from vibration, shock and pressure.

### Operating precautions

- It is important to operate the shutter within the specified voltage limits; higher voltages may significantly reduce the lifetime of the shutter.
- The use of direct current drive (DC voltage) should be avoided since a reaction stimulated by such current significantly reduces the lifetime of the shutter.
- The switching speed of the shutter will be reduced at lower temperatures, and the optical-shutter will show a dark color at higher temperatures. However, the shutter will revert to normal operation once the temperature conditions return to the range for normal operation.

### Safety

- Should the shutter become damaged and the skin is exposed to liquid crystal material, it is recommended to immediately wash off the liquid crystal material using soap and water.
- If the liquid crystal material should come into contact with the eye, flush the eye using running water for at least five minutes. Seek medical advice.